

# DURACELL *TIPS*

***TECHNICAL INFORMATION & PRODUCT SPECIFICATIONS***



**Print Output:** Ni-MH Technical Bulletin

Chapter: 1 & 2

Pages: 2 (not including this page)

# T able of Contents

---

## 1 Introduction

---

## 2 General Characteristics

---

## 3 Composition and Chemistry

- 3.1 Active Components: Positive and Negative Electrodes
  - 3.2 Electrolyte
  - 3.3 Cell Reactions
- 

## 4 Battery Construction

- 4.1 Basic Cell Construction
  - 4.2 Cylindrical Cell Construction
  - 4.3 Prismatic Cell Construction
- 

## 5 Performance Characteristics

- |   |  |
|---|--|
| 5.1 General Characteristics   | 5.5 Constant Power Discharge Characteristics |
| 5.2 Discharge Characteristics: Effect of Discharge Rate and Temperature | 5.6 Polarity Reversal During Overdischarge   |
| 5.3 Capacity: Effect of Discharge Rate and Temperature                  | 5.7 Internal Impedance                       |
| 5.4 Energy Density  | 5.8 Self-Discharge and Charge Retention      |
|   | 5.9 Voltage Depression (“Memory Effect”)     |
- 

## 6 Charging Sealed Nickel-Metal Hydride Batteries

- |   |   |
|---|---|
| 6.1 General Principles                          | 6.3 Charging Methods  |
| 6.2 Techniques for Charge Control               | 6.3.1 Duracell’s Recommendation:<br>Three-Step Charge Procedure |
| 6.2.1 Timed Charge                              | 6.3.2 Low-Rate Charge   |
| 6.2.2 Voltage Drop ( $-\Delta V$ )              | 6.3.3 Quick Charge  |
| 6.2.3 Voltage Plateau (zero $\Delta V$ )        | 6.3.4 Fast Charge   |
| 6.2.4 Temperature Cutoff                        | 6.3.5 Trickle Charge  |
| 6.2.5 Delta Temperature Cutoff ( $\Delta TCO$ ) | 6.4 Thermal Devices   |
| 6.2.6 Rate of Temperature Increase ( $dT/dt$ )  |   |
- 

## 7 Cycle and Battery Life

- 7.1 Cycle Life
  - 7.2 Battery Life
- 

## 8 Safety Considerations

---

## 9 Proper Use and Handling

- 9.1 Care and Handling
- 9.2 Transportation
- 9.3 Waste Management: Recycling and Disposal

# 1

## Introduction

Rapid advancements in electronic technology have expanded the number of battery-powered portable devices in recent years, stimulating consumer demand for higher-energy rechargeable batteries capable of delivering longer service between recharges or battery replacement.

The trend towards smaller, lighter more portable battery-powered devices is expected to continue well into the future, with the so-called “3C” applications — cellular phones, portable computers and consumer electronics — expanding rapidly beyond the traditional business user and into the consumer marketplace.

As with other battery-powered consumer devices, battery performance and convenience will influence the rate of consumer acceptance for 3C devices. Yet conventional rechargeable batteries often fail to meet the needs of consumers, as well as equipment designers, in terms of their size and weight, operating time, ease-of-use, availability and environmental acceptability. New battery systems are needed to meet their growing list of demands.

The sealed nickel-metal hydride (Ni-MH) battery is one rechargeable battery system that is responding to these demands by offering significant improvements over conventional rechargeable batteries in terms of performance and environmental friendliness. First introduced to the commercial market in 1988, nickel-metal hydride battery technology is at a very early stage of maturity and manufacturers such as Duracell have identified many opportunities to improve battery performance. These improvements will make DURACELL nickel-metal hydride batteries an attractive power source for 3C devices for many years to come.

# 2

## General Characteristics

Many of the operating characteristics of the sealed nickel-metal hydride rechargeable battery are similar to those of the sealed nickel-cadmium rechargeable battery. The nickel-metal hydride battery, however, has the advantage of higher energy density (or capacity) which translates into longer service life. In addition, the nickel-metal hydride battery is environmentally friendlier than nickel-cadmium and other battery systems because it contains no added cadmium, mercury or lead.

Features of the sealed nickel-metal hydride battery include:

- **Higher capacity** — Up to 40 percent longer service life than ordinary nickel-cadmium batteries of equivalent size.
- **High rate discharge** — Efficient discharge at rates as high as 2C.
- **Fast charge** — Can be charged in approximately one hour.
- **Safe** — Designed to safely withstand abusive conditions in consumer devices.
- **Long cycle life** — Up to 500 charge/discharge cycles.
- **Performs at extreme temperatures** — Capable of operation on discharge from -20°C to 50°C (-4°F to 122°F) and charge from 0°C to 45°C (32°F to 113°F).
- **Environmentally friendlier than nickel-cadmium batteries** — Zero percent cadmium.
- **Similar operating voltage to nickel-cadmium batteries** — Allows user to upgrade easily to longer lasting nickel-metal hydride batteries.

# DURACELL *TIPS*

***TECHNICAL INFORMATION & PRODUCT SPECIFICATIONS***



**Print Output:** Ni-MH Technical Bulletin

Chapter: 3

Pages: 3 (not including this page)

# T able of Contents

---

## 1 Introduction

---

## 2 General Characteristics

---

## 3 Composition and Chemistry

- 3.1 Active Components: Positive and Negative Electrodes
  - 3.2 Electrolyte
  - 3.3 Cell Reactions
- 

## 4 Battery Construction

- 4.1 Basic Cell Construction
  - 4.2 Cylindrical Cell Construction
  - 4.3 Prismatic Cell Construction
- 

## 5 Performance Characteristics

- |   |  |
|---|--|
| 5.1 General Characteristics   | 5.5 Constant Power Discharge Characteristics |
| 5.2 Discharge Characteristics: Effect of Discharge Rate and Temperature | 5.6 Polarity Reversal During Overdischarge   |
| 5.3 Capacity: Effect of Discharge Rate and Temperature                  | 5.7 Internal Impedance                       |
| 5.4 Energy Density  | 5.8 Self-Discharge and Charge Retention      |
|   | 5.9 Voltage Depression (“Memory Effect”)     |
- 

## 6 Charging Sealed Nickel-Metal Hydride Batteries

- |   |   |
|---|---|
| 6.1 General Principles                          | 6.3 Charging Methods  |
| 6.2 Techniques for Charge Control               | 6.3.1 Duracell’s Recommendation:<br>Three-Step Charge Procedure |
| 6.2.1 Timed Charge                              | 6.3.2 Low-Rate Charge   |
| 6.2.2 Voltage Drop ( $-\Delta V$ )              | 6.3.3 Quick Charge  |
| 6.2.3 Voltage Plateau (zero $\Delta V$ )        | 6.3.4 Fast Charge   |
| 6.2.4 Temperature Cutoff                        | 6.3.5 Trickle Charge  |
| 6.2.5 Delta Temperature Cutoff ( $\Delta TCO$ ) | 6.4 Thermal Devices   |
| 6.2.6 Rate of Temperature Increase ( $dT/dt$ )  |   |
- 

## 7 Cycle and Battery Life

- 7.1 Cycle Life
  - 7.2 Battery Life
- 

## 8 Safety Considerations

---

## 9 Proper Use and Handling

- 9.1 Care and Handling
- 9.2 Transportation
- 9.3 Waste Management: Recycling and Disposal

# 3

## Composition and Chemistry

A rechargeable battery is based on the principle that the charge/discharge process is reversible, that is, the energy delivered by the battery during discharge can be replaced or restored by recharging.

### 3.1 Active Components: Positive and Negative Electrodes

Nickel oxyhydroxide (NiOOH) is the active material in the positive electrode of the nickel-metal hydride battery in the charged state, the same as in the nickel-cadmium battery.

The negative active material, in the charged state, is hydrogen in the form of a metal hydride. This metal alloy is capable of undergoing a reversible hydrogen absorbing/desorbing reaction as the battery is charged and discharged, respectively.

The unique attribute of the hydrogen storage alloy is its ability to store hundreds of times its own volume of hydrogen gas at a pressure less than atmospheric pressure. Many different intermetallic compounds have been evaluated as electrode materials for nickel-metal hydride batteries. Typically, these fall into two classes: AB<sub>5</sub> alloys, of which LaNi<sub>5</sub> is an example, and AB<sub>2</sub>

alloys, of which TiMn<sub>2</sub> or ZrMn<sub>2</sub> are examples.

DURACELL nickel-metal hydride battery technology is based on the use of AB<sub>5</sub> instead of AB<sub>2</sub> alloys. AB<sub>5</sub> alloys offer better corrosion resistance characteristics, resulting in longer cycle life and better rechargability following storage. The composition of the metal alloy is formulated for optimal stability over a large number of charge/discharge cycles. Other important properties of the alloy include:

- Large hydrogen storage capability for high energy density and battery capacity.
- Favorable kinetic properties for high rate capability during charge and discharge.
- Low hydrogen pressure alloy and high purity materials to minimize self-discharge.

### 3.2 Electrolyte

An aqueous solution of potassium hydroxide is the major component of the electrolyte of a nickel-metal hydride battery. A minimum amount of electrolyte is used in this sealed cell design, with most of

this liquid being absorbed by the separator and the electrodes. This “starved electrolyte” design facilitates the diffusion of oxygen to the negative electrode at the end-of-charge for the “oxygen recombination” reaction.

### 3.3 Cell Reactions

During discharge, the nickel oxyhydroxide is reduced to nickel hydroxide

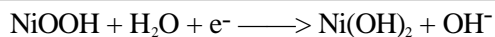

and the metal hydride (MH) is oxidized to the metal alloy (M).

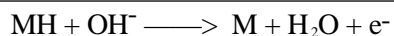

The overall reaction on discharge is:

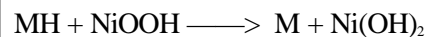

The process is reversed during charge.

**Composition and Chemistry (cont.)**

The sealed nickel-metal hydride cell uses the “oxygen-recombination” mechanism to prevent a build-up of pressure that may result from the generation of oxygen towards the end of charge and overcharge. This mechanism requires the use of a negative electrode (the metal hydride/metal electrode) which has a higher effective capacity than the positive (nickel oxyhydroxide/nickel hydroxide electrode) electrode. A schematic drawing of the electrodes is shown in **Figure 3.3.1**.

During charge, the positive electrode reaches full charge before the negative electrode which causes the evolution of oxygen to begin:

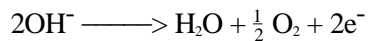

The oxygen gas diffuses through the separator to the negative electrode, a process which is facilitated by the “starved-electrolyte” design and the selection of an appropriate separator system.

At the negative electrode, the oxygen reacts with the metal hydride and oxidizes or discharges the metal hydride to produce water:

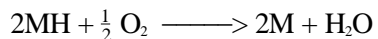

Thus, the negative electrode does not become fully charged and pressure does not build up.

The charge current, however, must be controlled at the end of charge and during overcharge to limit the generation of oxygen to below the rate of recombination. Thus, charge control is required to prevent the build-up of gases and pressure. Duracell recommends that continuous overcharge not exceed C/300 for optimal performance.

As shown in **Figure 3.3.1**, the nickel-metal hydride cell is designed with a discharge and charge reserve in the negative electrode. The discharge reserve minimizes gassing and degradation of the cell in the event of overdischarge. The charge reserve ensures that the cell maintains low internal pressure on overcharge.

The negative electrode has excess capacity compared to the positive electrode and is used to handle both overcharge and overdischarge. Thus, the useful capacity of the battery is determined by the positive electrode.

**FIGURE 3.3.1**

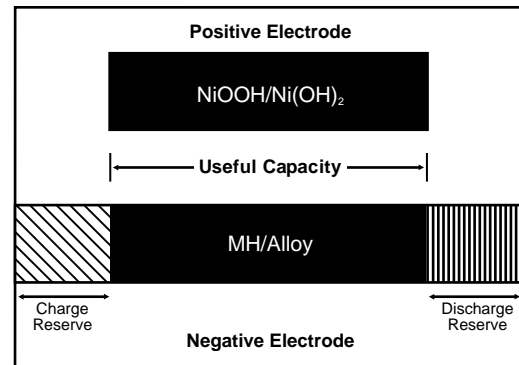

**Schematic representation of the electrodes, divided into useful capacity, charge reserve and discharge reserve.**

# DURACELL *TIPS*

***TECHNICAL INFORMATION & PRODUCT SPECIFICATIONS***



**Print Output:** Ni-MH Technical Bulletin

Chapter: 4

Pages: 3 (not including this page)

# T able of Contents

---

## 1 Introduction

---

## 2 General Characteristics

---

## 3 Composition and Chemistry

- 3.1 Active Components: Positive and Negative Electrodes
  - 3.2 Electrolyte
  - 3.3 Cell Reactions
- 

## 4 Battery Construction

- 4.1 Basic Cell Construction
  - 4.2 Cylindrical Cell Construction
  - 4.3 Prismatic Cell Construction
- 

## 5 Performance Characteristics

- 5.1 General Characteristics
  - 5.2 Discharge Characteristics: Effect of Discharge Rate and Temperature
  - 5.3 Capacity: Effect of Discharge Rate and Temperature
  - 5.4 Energy Density
  - 5.5 Constant Power Discharge Characteristics
  - 5.6 Polarity Reversal During Overdischarge
  - 5.7 Internal Impedance
  - 5.8 Self-Discharge and Charge Retention
  - 5.9 Voltage Depression (“Memory Effect”)
- 

## 6 Charging Sealed Nickel-Metal Hydride Batteries

- 6.1 General Principles
  - 6.2 Techniques for Charge Control
    - 6.2.1 Timed Charge
    - 6.2.2 Voltage Drop ( $-\Delta V$ )
    - 6.2.3 Voltage Plateau (zero  $\Delta V$ )
    - 6.2.4 Temperature Cutoff
    - 6.2.5 Delta Temperature Cutoff ( $\Delta TCO$ )
    - 6.2.6 Rate of Temperature Increase ( $dT/dt$ )
  - 6.3 Charging Methods
    - 6.3.1 Duracell’s Recommendation: Three-Step Charge Procedure
    - 6.3.2 Low-Rate Charge
    - 6.3.3 Quick Charge
    - 6.3.4 Fast Charge
    - 6.3.5 Trickle Charge
  - 6.4 Thermal Devices
- 

## 7 Cycle and Battery Life

- 7.1 Cycle Life
  - 7.2 Battery Life
- 

## 8 Safety Considerations

---

## 9 Proper Use and Handling

- 9.1 Care and Handling
- 9.2 Transportation
- 9.3 Waste Management: Recycling and Disposal

# 4

## Battery Construction

DURACELL standard-sized nickel-metal hydride batteries are constructed with cylindrical and prismatic nickel-metal hydride cells. DURACELL nickel-metal hydride batteries are a sealed construction designed for optimal performance and maximum safety. The batteries are manufactured to strict quality control standards to ensure reliability and consumer satisfaction and offer such features as:

- **High energy density** — Minimizes battery volume and weight
- **Wide voltage range** — Meets operating voltage requirements of 3C devices
- **Thin profiles** — Innovative wall-less design
- **Advanced interconnect** — Self securing, voltage-keyed interconnect provides a highly reliable battery-to-device contact
- **Durability** — Manufactured with LEXAN® and LUSTRAN® polycarbonate high impact and flame retardant polymers
- **UL listing** — Independent approval of battery use in devices

LEXAN® is a registered trademark of the General Electric Company.  
LUSTRAN® is a registered trademark of the Monsanto Company.

### 4.1 Basic Cell Construction

The electrodes in both cylindrical and prismatic cell configurations are designed with highly porous structures which have large surface areas to provide low internal resistance which results in superior high rate performance. The positive electrode in the cylindrical

nickel-metal hydride cell is a highly porous nickel-felt substrate into which the nickel compounds are pasted. Similarly, the negative electrode is a perforated nickel-plated steel foil onto which the plastic-bonded, active hydrogen storage alloy is coated.

### 4.2 Cylindrical Cell Construction

The assembly of a cylindrical cell is shown in **Figure 4.2.1**. The electrodes are separated by the separator which is a synthetic, non-woven material that serves as an insulator between the two electrodes and as a medium for absorbing the electrolyte. The electrodes are spirally-wound and inserted into a cylindrical nickel-plated steel can. The electrolyte is added and contained within the pores of the electrodes and separator.

The positive electrode is connected to the metal lid with a tab. The cell is then sealed by crimping the

top assembly to the can. The top assembly incorporates a resealable safety vent, a metal lid and a plastic gasket. A heat-shrink tube is placed over the metal can. The bottom of the metal can serves as the negative terminal and the metal lid as the positive terminal. The insulator and gasket insulate the terminals from each other. The vent provides additional safety by releasing any excess pressure that may build up if the battery is subjected to abusive conditions.

FIGURE 4.2.1

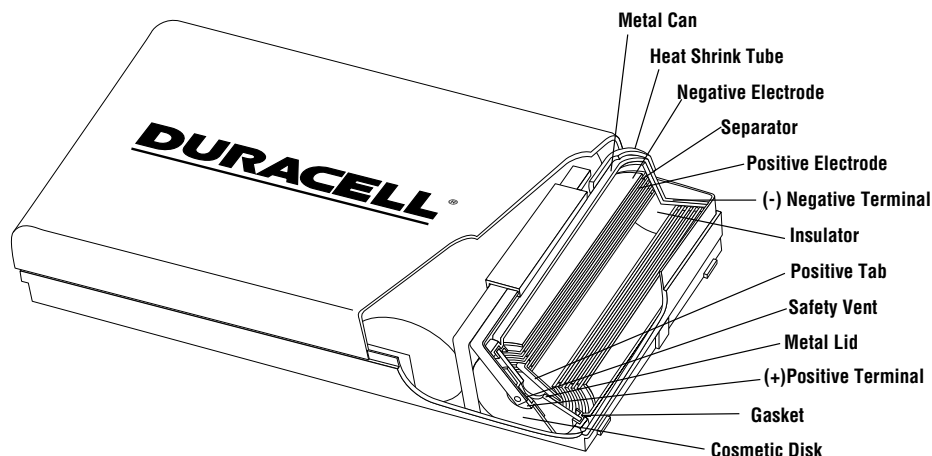

## Battery Construction (cont.)

### 4.3 Prismatic Cell Construction

The basic differences between the prismatic cell and the cylindrical cell are the construction of the electrodes and the shape of the can. Prismatic cells are designed to meet the needs of compact equipment where space for the battery is limited. The rectangular shape of the prismatic cell permits more efficient battery assembly by eliminating the voids that occur in a battery constructed with cylindrical cells. Thus, the volumetric energy density of a battery can be increased by constructing it with prismatic instead of cylindrical cells.

**Figure 4.3.1** shows the structure of the prismatic nickel-metal hydride cell. The electrodes are manufactured in a manner similar to those of the cylindrical cell, except that the finished electrodes are flat and rectangular in shape. The positive and negative electrodes are interspaced by separator sheets. The assembly is then placed in a nickel-plated steel can and the electrolyte is added. The positive electrodes are connected to the metal lid with a tab. The cell is then sealed by crimping the top assembly to the can. The top assembly incorporates a resealable safety vent, a metal lid and a plastic gasket that is similar to the one used in the cylindrical cell. A heat-shrink tube is placed over the metal can. The bottom of the metal can serves as the negative terminal and the top metal lid as the positive terminal. The insulator and gasket insulate the terminals from each other. The vent provides additional safety by re-releasing any excess pressure that may build up if the battery is subjected to abusive conditions.

**FIGURE 4.3.1**

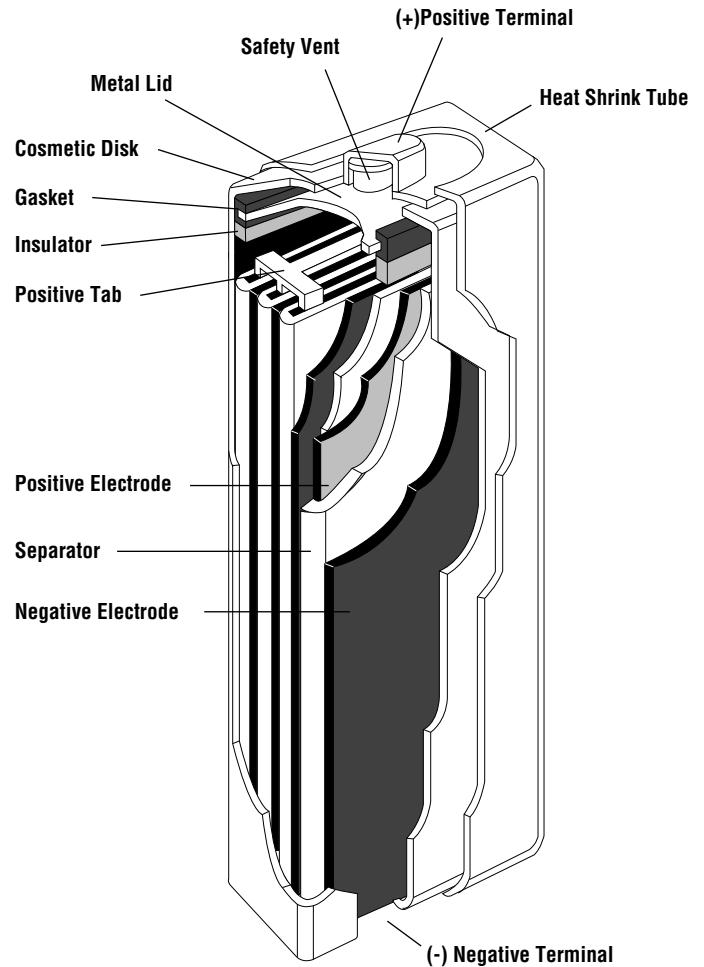

# DURACELL *TIPS*

***TECHNICAL INFORMATION & PRODUCT SPECIFICATIONS***



**Print Output:** Ni-MH Technical Bulletin

Chapter: 5

Pages: 6 (not including this page)

# T able of Contents

---

## 1 Introduction

---

## 2 General Characteristics

---

## 3 Composition and Chemistry

- 3.1 Active Components: Positive and Negative Electrodes
  - 3.2 Electrolyte
  - 3.3 Cell Reactions
- 

## 4 Battery Construction

- 4.1 Basic Cell Construction
  - 4.2 Cylindrical Cell Construction
  - 4.3 Prismatic Cell Construction
- 

## 5 Performance Characteristics

- 5.1 General Characteristics
  - 5.2 Discharge Characteristics: Effect of Discharge Rate and Temperature
  - 5.3 Capacity: Effect of Discharge Rate and Temperature
  - 5.4 Energy Density
  - 5.5 Constant Power Discharge Characteristics
  - 5.6 Polarity Reversal During Overdischarge
  - 5.7 Internal Impedance
  - 5.8 Self-Discharge and Charge Retention
  - 5.9 Voltage Depression (“Memory Effect”)
- 

## 6 Charging Sealed Nickel-Metal Hydride Batteries

- 6.1 General Principles
  - 6.2 Techniques for Charge Control
    - 6.2.1 Timed Charge
    - 6.2.2 Voltage Drop ( $-\Delta V$ )
    - 6.2.3 Voltage Plateau (zero  $\Delta V$ )
    - 6.2.4 Temperature Cutoff
    - 6.2.5 Delta Temperature Cutoff ( $\Delta TCO$ )
    - 6.2.6 Rate of Temperature Increase ( $dT/dt$ )
  - 6.3 Charging Methods
    - 6.3.1 Duracell’s Recommendation: Three-Step Charge Procedure
    - 6.3.2 Low-Rate Charge
    - 6.3.3 Quick Charge
    - 6.3.4 Fast Charge
    - 6.3.5 Trickle Charge
  - 6.4 Thermal Devices
- 

## 7 Cycle and Battery Life

- 7.1 Cycle Life
  - 7.2 Battery Life
- 

## 8 Safety Considerations

---

## 9 Proper Use and Handling

- 9.1 Care and Handling
- 9.2 Transportation
- 9.3 Waste Management: Recycling and Disposal

# 5

## Performance Characteristics

### 5.1 General Characteristics

The discharge characteristics of the nickel-metal hydride cell are very similar to those of the nickel-cadmium cell. The charged open circuit voltage of both systems ranges from 1.25 to 1.35 volts per cell. On discharge, the nominal voltage is 1.2 volts per cell and the typical end voltage is 1.0 volt per cell.

**Figure 5.1.1** illustrates the discharge characteristics of nickel-metal hydride and nickel-cadmium rechargeable cells of the same size. As shown, the voltage profile of both types of cells is flat throughout most of the discharge. The midpoint voltage can range from 1.25 to 1.1 volts per cell, depending on the discharge load. **Figure 5.1.1** can also be used to compare the capacity of the two rechargeable types. Note that the capacity of the nickel-metal hydride cell is typically up to 40 percent higher than that of a nickel-cadmium cell of equivalent size.

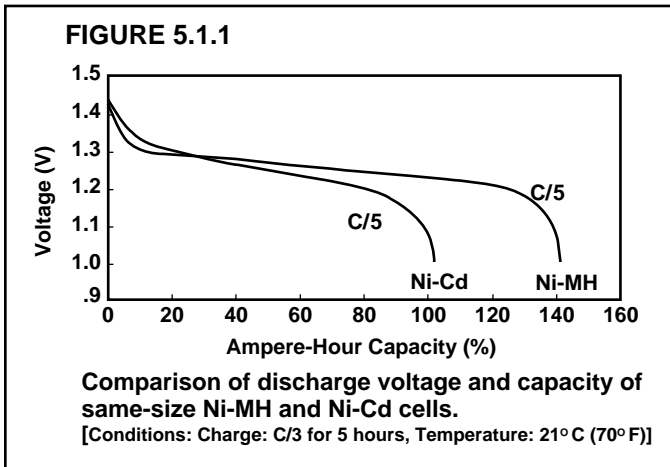

### 5.2 Discharge Characteristics: Effect of Discharge Rate and Temperature

Typical discharge curves for DURACELL nickel-metal hydride batteries under constant current loads at various temperatures are shown in **Figures 5.2.1 to 5.2.3**. Discharge voltage is dependent on discharge current and discharge temperature.

**FIGURE 5.2.1**

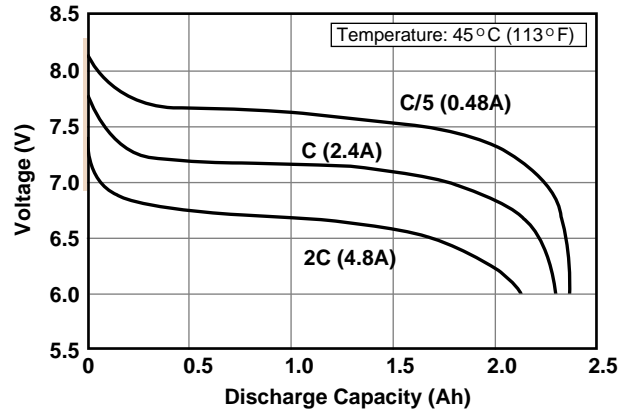

**FIGURE 5.2.2**

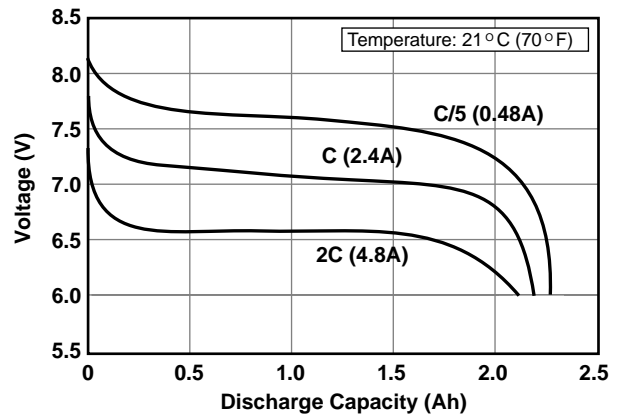

**FIGURE 5.2.3**

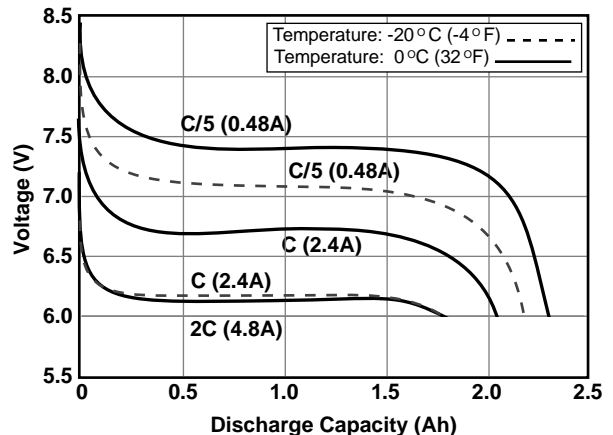

Voltage and capacity of DURACELL DR30 Ni-MH batteries at various discharge temperatures and rates.

[Conditions: Charge: 1C to  $-\Delta V = 60mV @ 21^\circ C (70^\circ F)$ ]

### Performance Characteristics (cont.)

Typically, when the current is higher and the temperature is lower, the operating voltage will be lower. This is due to the higher “IR” drop that occurs with increasing current and the cell’s increasing resistance at the lower temperatures. However, at moderate discharge rates ( $\approx C/5$ ), the effect of low temperature on the capacity of the nickel-metal hydride battery is minimal.

#### 5.3 Capacity: Effect of Discharge Rate and Temperature

The ampere-hour capacity of the battery is dependent on the discharge current and temperature, as can be observed in **Figure 5.3.1**. It should be noted that the delivered capacity is dependent on the cutoff or end voltage. The delivered capacity can be increased by continuing the discharge to lower end voltages. However, the battery should not be discharged to too low a cut-off voltage (less than 0.9 volts per cell) as the cells may be damaged (see Section 5.6). The recommended cutoff voltage for nickel-metal hydride batteries is 1.0 volt per cell.

Typically, optimum performance of the nickel-metal hydride battery is obtained between 0°C and 45°C (32°F and 113°F). The performance characteristics of the battery are affected moderately at higher temperatures. At lower discharge temperatures, performance decreases more significantly, caused primarily by the increase in internal resistance. Similarly, the effects of temperature on performance are more pronounced at higher discharge rates. The capacity of the battery decreases more noticeably as the current increases, particularly at lower temperatures.

#### 5.4 Energy Density

Energy density is the ratio of the energy available from a battery to its volume or weight. A comparison of the performance of various battery systems is normally made on practical, delivered energy density per-unit-weight or volume using production-based batteries and performance as opposed to theoretical energy density. Comparing energy densities, one must consider the influence of cell size, internal design, discharge rate and temperature conditions, as these parameters strongly impact performance characteristics.

**FIGURE 5.3.1**

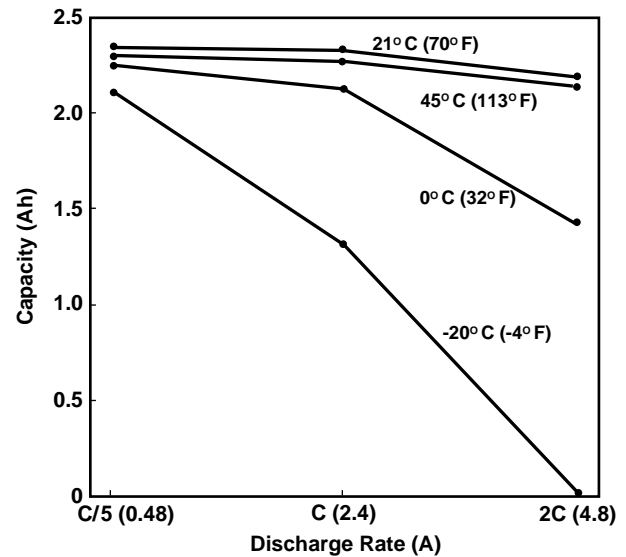

**Typical capacity of DURACELL DR30 batteries under constant current discharges at various temperatures.**

[Conditions: Charge: 1C to  $-\Delta V = 60\text{mV}$  @ 21°C (70°F); Discharge to 6.0V]

**Performance Characteristics (cont.)**

**Figure 5.4.1** compares the gravimetric and volumetric energy density of nickel-metal hydride and nickel-cadmium cells. As indicated, nickel-metal hydride cells deliver more energy per weight or volume than nickel-cadmium cells.

**5.5 Constant Power Discharge Characteristics**

The output energy characteristic of nickel-metal hydride batteries under the constant power mode at different power levels is shown in **Figure 5.5.1**. As illustrated, the energy delivered does not vary significantly with increasing power. The power levels are shown on the basis of E-Rate. The E-Rate is calculated in a manner similar to calculating the C-Rate. For example, at the E/10 power level, the power for a battery rated at 17.3 watt-hours is 1.73 watts.

**5.6 Polarity Reversal During Overdischarge**

When cells are connected in series, the cell with the lowest capacity will reach a lower point of discharge than the others. The more cells that are connected in series, the greater the possibility of a cell being fully discharged and driven into overdischarge and polarity reversal. During reversal, hydrogen gas evolves from the positive electrode. Hydrogen gas will be reabsorbed by the negative electrode and eventually oxygen gas will evolve from the negative electrode. Extended overdischarge will lead to elevated cell pressure and opening of the safety vent within the nickel-metal hydride cells.

To minimize the occurrence of polarity reversal, the cells in DURACELL rechargeable batteries have capacities that are “matched” to each other. Device designers can help prevent overdischarge by designing a cutoff voltage for device operation of 1.0 volt per cell.

**FIGURE 5.4.1**

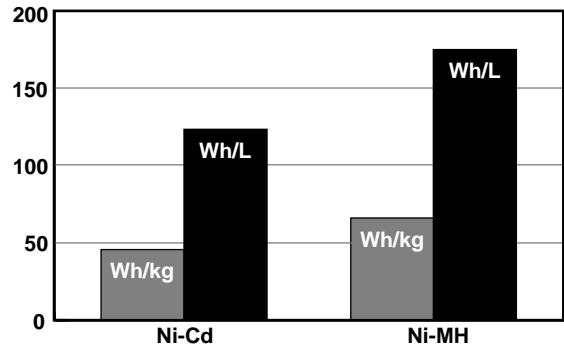

**Gravimetric and volumetric energy density of Ni-Cd and Ni-MH cells.**

**FIGURE 5.5.1**

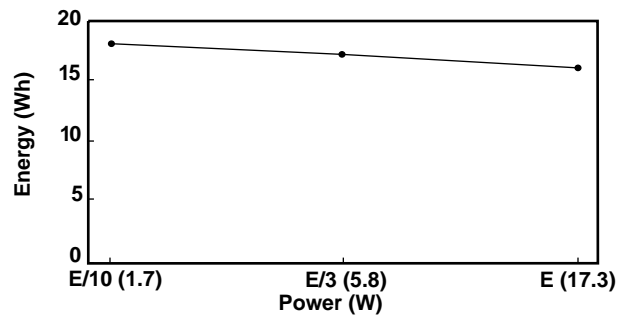

**Typical energy of DURACELL DR30 batteries under constant power discharges.**

[Conditions: Charge: 1C to  $\Delta V = 60mV$ ; Discharge to 6.0V; Temperature: 21° C (70° F)]

**Performance Characteristics (cont.)**

**5.7 Internal Impedance**

DURACELL nickel-metal hydride batteries have low internal impedance because they are manufactured using cells designed with thin plate electrodes which offer large surface areas and good conductivity. **Figure 5.7.1** shows the change in internal impedance with depth of discharge. As demonstrated, the impedance remains relatively constant during most of the discharge. Towards the end of the discharge, the impedance increases due to the conversion of the active materials to a non-conductive form.

**5.8 Self-Discharge and Charge Retention**

The state-of-charge and capacity of the nickel-metal hydride battery decrease during storage due to self-discharge of the cells. Self-discharge results from the reaction of residual hydrogen in the battery with the positive electrode, as well as the slow and reversible decomposition of the positive electrode. The rate of self-discharge is dependent upon the length of time and temperature at which the battery is stored — the higher the temperature, the greater the rate of self-discharge. As illustrated in **Figure 5.8.1**, cells stored at 0°C (32°F) retain more of their capacity than those stored at 20°C and 45°C (68°F and 113°F), particularly after 30 days.

Generally, long term storage of a nickel-metal hydride battery in either a charged or discharged condition has no permanent effect on capacity. Capacity loss due to self-discharge is reversible and nickel-metal hydride batteries can recover to full capacity by proper recharging. For example, full capacity of a nickel-metal hydride battery that was stored at room temperature for up to one year can be restored by cycling through repeated charge/discharge cycles.

As with operation at elevated temperatures, however, long term storage at high temperatures can lead to deterioration of seals and separators and should be avoided. The recommended temperature range for long term storage of nickel-metal hydride batteries is 10°C to 30°C (50°F to 86°F).

**FIGURE 5.7.1**

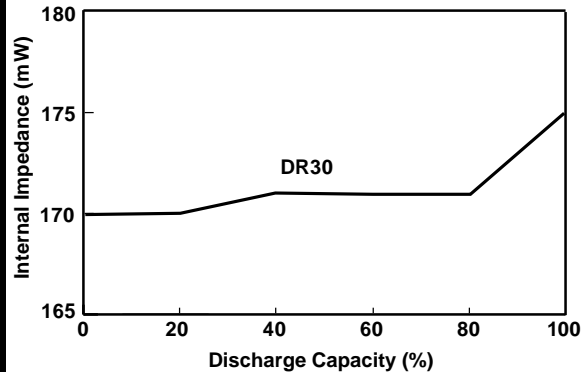

**Internal impedance of DURACELL DR30 Ni-MH batteries at various discharge capacities.**

[Conditions: Charge: C/5 for 7.5 hours; Discharge: C/5; Temperature: 21°C (70°F); Measurements at 1000 Hz]

**FIGURE 5.8.1**

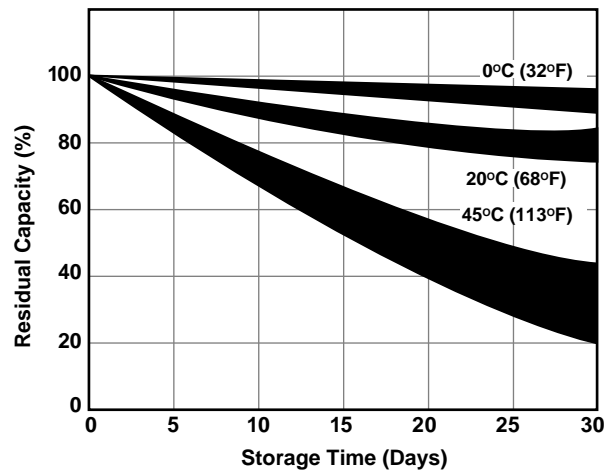

**Self-discharge characteristic of Ni-MH cells at various temperatures.**

[Conditions: Charge: C/3 for 5 hours; Discharge: C/5 to 1.0V; Temperature: 21°C (70°F)]

### Performance Characteristics (cont.)

#### 5.9 Voltage Depression (“Memory Effect”)

Although many years of premium performance can be enjoyed from a nickel-metal hydride battery that is properly handled, the capacity delivered in each charge/discharge cycle will eventually begin to decrease. This inevitable decrease in capacity can be accelerated by overcharging, storage or usage at high temperatures, or through poor matching of cells within a pack. Often, battery users who experience short service life have incorrectly attributed capacity loss to a phenomenon called “memory effect.”

The term memory effect is used synonymously with the term “voltage depression.” Voltage depression is a scientifically measurable characteristic of all batteries, however, nickel-cadmium batteries demonstrate particularly acute sensitivity. A properly designed application with nickel-metal hydride batteries will result in neither permanent performance loss nor perceivable temporary capacity decreases from this characteristic.

A reversible drop in voltage and loss of capacity may occur when a nickel-metal hydride battery is partially discharged and recharged repetitively without the benefit of a full discharge, as illustrated in **Figure 5.9.1**. After an initial full discharge (Cycle #1) and charge, the cell is partially discharged to 1.15 volts and recharged for a number of cycles. During this cycling, the discharge voltage and capacity drop gradually in very small increments (Cycles #2 to #18). On a subsequent full discharge (Cycle #19), the discharge voltage is depressed compared to the original full discharge (Cycle #1).

Because the cell appears to “remember” the lower capacity, this voltage depression phenomenon is often referred to as memory effect. However, the cell can be quickly restored to full capacity with a few full discharge/charge cycles, as indicated in Cycles #20 and #21.

The voltage drop occurs because only a portion of the active materials in the cell is discharged and recharged during shallow or partial discharging. The active materials that have not been cycled change in

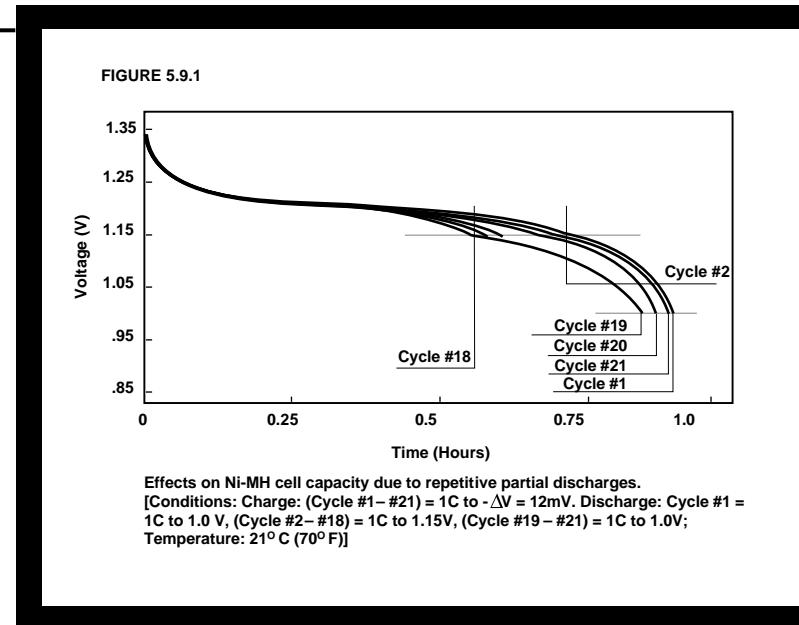

physical characteristics and increase in resistance. Subsequent full discharge/charge cycling will restore the active materials to their original state.

The extent of voltage depression and capacity loss depends on depth of discharge and can be avoided by discharging the battery to an appropriate cutoff voltage. Voltage depression is most apparent when the discharge is terminated at higher cutoff voltages, such as 1.2 volts per cell. A smaller voltage depression and capacity loss occurs if the discharge is cut off between 1.15 volts to 1.10 volts per cell. Discharging to 1.0 volts per cell should not result in significant voltage depression or capacity loss during subsequent discharges.

A device properly designed with nickel-metal hydride batteries will minimize the effects of voltage depression and capacity loss. The voltage depression and capacity loss in DURACELL nickel-metal hydride batteries is only a small fraction (less than 5 percent in worst cases) of the battery’s capacity and most users will never experience a perceptible performance loss.

# DURACELL *TIPS*

***TECHNICAL INFORMATION & PRODUCT SPECIFICATIONS***



**Print Output:** Ni-MH Technical Bulletin

Chapter: 6

Pages: 7 (not including this page)

# T able of Contents

---

## 1 Introduction

---

## 2 General Characteristics

---

## 3 Composition and Chemistry

- 3.1 Active Components: Positive and Negative Electrodes
  - 3.2 Electrolyte
  - 3.3 Cell Reactions
- 

## 4 Battery Construction

- 4.1 Basic Cell Construction
  - 4.2 Cylindrical Cell Construction
  - 4.3 Prismatic Cell Construction
- 

## 5 Performance Characteristics

- |   |  |
|---|--|
| 5.1 General Characteristics   | 5.5 Constant Power Discharge Characteristics |
| 5.2 Discharge Characteristics: Effect of Discharge Rate and Temperature | 5.6 Polarity Reversal During Overdischarge   |
| 5.3 Capacity: Effect of Discharge Rate and Temperature                  | 5.7 Internal Impedance                       |
| 5.4 Energy Density  | 5.8 Self-Discharge and Charge Retention      |
|   | 5.9 Voltage Depression (“Memory Effect”)     |
- 

## 6 Charging Sealed Nickel-Metal Hydride Batteries

- |   |   |
|---|---|
| 6.1 General Principles                          | 6.3 Charging Methods  |
| 6.2 Techniques for Charge Control               | 6.3.1 Duracell’s Recommendation:<br>Three-Step Charge Procedure |
| 6.2.1 Timed Charge                              | 6.3.2 Low-Rate Charge   |
| 6.2.2 Voltage Drop ( $-\Delta V$ )              | 6.3.3 Quick Charge  |
| 6.2.3 Voltage Plateau (zero $\Delta V$ )        | 6.3.4 Fast Charge   |
| 6.2.4 Temperature Cutoff                        | 6.3.5 Trickle Charge  |
| 6.2.5 Delta Temperature Cutoff ( $\Delta TCO$ ) | 6.4 Thermal Devices   |
| 6.2.6 Rate of Temperature Increase ( $dT/dt$ )  |   |
- 

## 7 Cycle and Battery Life

- 7.1 Cycle Life
  - 7.2 Battery Life
- 

## 8 Safety Considerations

---

## 9 Proper Use and Handling

- 9.1 Care and Handling
- 9.2 Transportation
- 9.3 Waste Management: Recycling and Disposal

# 6

### 6.1 General Principles

Recharging is the process of replacing energy that has been discharged from the battery. The subsequent performance of the battery, as well as its overall life, is dependent on effective charging. The main criteria for effective charging are:

- Choosing the appropriate rate
- Limiting the temperature
- Selecting the appropriate termination technique

The recharging characteristics of nickel-metal hydride batteries are generally similar to those of nickel-cadmium batteries. There are some distinct differences, however, particularly on the requirements for charge control because the nickel-metal hydride battery is more sensitive to overcharging. Caution should be exercised before using a nickel-cadmium battery charger interchangeably for both battery types because it may not optimally charge a nickel-metal hydride battery, particularly on high rate chargers.

The most common charging method for the nickel-metal hydride battery is a constant current charge with the current limited in order to avoid an excessive rise in temperature. Limiting the charge current also reduces the risk of exceeding the rate of the oxygen recombination reaction to prevent cell venting.

**Figure 6.1.1** compares the voltage profiles of nickel-metal hydride and nickel-cadmium batteries during charge at a constant current rate. The voltages of both systems rise as the batteries accept the charge. As the batteries approach 75 to 80 percent charge, the voltages of both battery types rise more sharply due to the generation of oxygen at the positive electrode. However, as the batteries go into overcharge, the voltage profile of the nickel-metal hydride battery does not exhibit as prominent a voltage drop as the nickel-cadmium battery.

In **Figure 6.1.2**, the temperature profiles of the nickel-metal hydride and nickel-cadmium batteries are compared during charge at a constant current charge rate. Throughout the first 80 percent of charge, the temperature of the nickel-cadmium battery rises gradually because its charge reaction is endothermic (absorbs heat). The temperature of the nickel-metal hydride

FIGURE 6.1.1

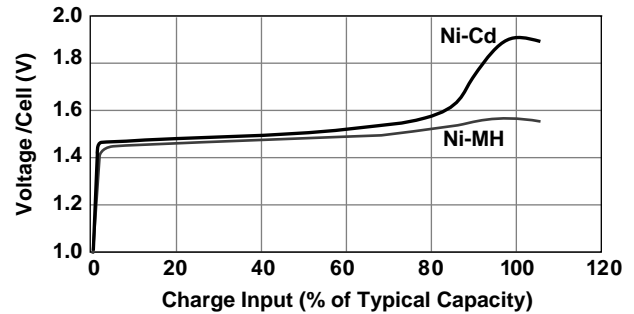

Typical charge voltage characteristics of Ni-MH and Ni-Cd batteries.

[Conditions: Charge: 1C @ 21°C (70°F) to  $-\Delta V = 10\text{mV/cell}$ ]

FIGURE 6.1.2

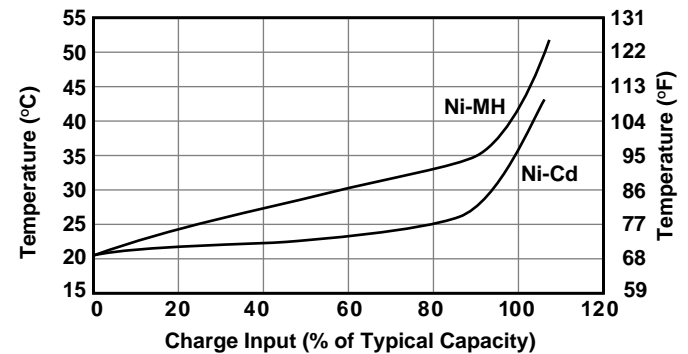

Typical charge temperature characteristics of Ni-MH and Ni-Cd batteries.

[Conditions: Charge: 1C @ 21°C (70°F) to  $-\Delta V = 10\text{mV/cell}$ ]

battery, on the other hand, rises quickly because its charge reaction is exothermic (releases heat). After 80 to 85 percent of charge, the temperature of both battery types also rises due to the exothermic oxygen recombination reaction, causing the voltage to drop as the batteries reach full charge and go into overcharge.

Both the voltage drop after peaking ( $-\Delta V$ ) and the temperature rise are used as methods to terminate the charge. Thus, while similar charge techniques can be used for nickel-metal hydride and nickel-cadmium batteries, the conditions to terminate the charge may differ because of the varying behavior of the two battery systems during charge. To properly terminate charging of DURACELL nickel-metal hydride batteries,

### Charging Sealed Nickel-Metal Hydride Batteries (cont.)

Duracell recommends the charge termination method described in Section 6.3.1.

The voltage of the nickel-metal hydride battery during charge depends on a number of conditions, including charge current and temperature. **Figures 6.1.3** and **6.1.4** show the voltage profile of the nickel-metal hydride battery at different ambient temperatures and charge rates, respectively. The battery voltage rises with an increase in charge current due to an increase in the “IR” drop and overpotential during the electrode reaction. The battery voltage decreases with increasing temperature as the internal resistance and overpotential during the electrode reaction decrease.

A rise in temperature and pressure at high charge rates occurs and underscores the need for proper charge control and effective charge termination when “fast charging.” Excessive pressure and temperature increases can result in activation of cell vents or battery safety electronics, as described in Section 6.4.

Temperature also affects charge efficiency. Charge efficiency decreases at higher temperatures due to the increasing evolution of oxygen at the positive electrode. Thus, charging at high temperatures results in lower capacity. At lower temperatures, charge efficiency is high due to decreasing oxygen evolution. However, oxygen recombination is slower at lower temperatures and a rise in internal cell pressure may occur depending on the charge rate.

Proper charging is critical not only to obtain maximum capacity on subsequent discharges but also to avoid high internal temperatures, excessive overcharge and other conditions which could adversely affect battery life.

## 6.2 Techniques for Charge Control

The characteristics of the nickel-metal hydride battery define the need for proper charge control in order to terminate the charge and prevent overcharging or exposure to high temperatures. Each charge control technique has its advantages and disadvantages. For example, higher capacity levels are achieved with a 150 percent charge input, but at the expense of cycle life; long cycle life is attained with a 105 to 110 percent charge input, albeit with slightly lower capacity due to

**FIGURE 6.1.3**

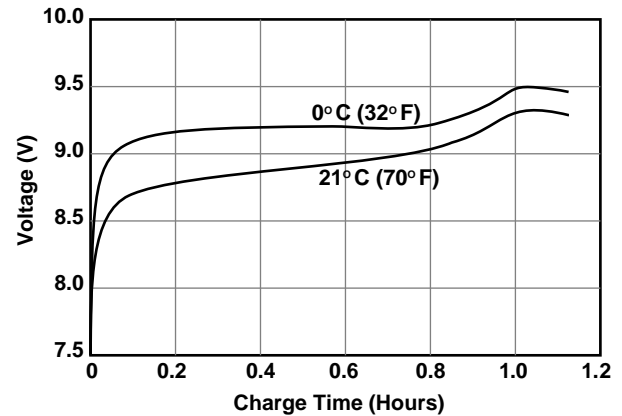

**Charge voltage of DURACELL DR30 Ni-MH batteries at various temperatures.**

[Conditions: Discharge: C/5 to 6.0V @ 21°C (70°F); Charge: 1C to  $-\Delta V = 60\text{mV}$ ]

**FIGURE 6.1.4**

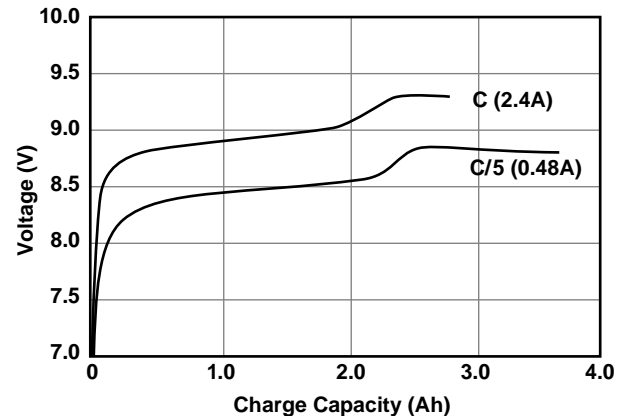

**Charge voltage of DURACELL DR30 Ni-MH batteries at various rates.**

[Conditions: Discharge: C/5 to 6.0V; Charge: 1C to  $-\Delta V = 60\text{mV}$ , C/5 to 7.5 hrs.; Temperature: 21°C (70°F)]

less charge input. Thermal cutoff charge control may reduce cycle life because higher temperatures are reached during the charge; however, it is useful as a backup control in the event that the primary termination method is not effective during charge.

### Charging Sealed Nickel-Metal Hydride Batteries (cont.)

The following summary explains some of the recommended methods for charge control. The characteristics of each of these methods are illustrated in **Figure 6.2.1**. In many cases, several methods are employed, particularly for high rate charging.

#### 6.2.1 Timed Charge

Under the timed charge control method, the charge is terminated after the battery is charged for a predetermined length of time. This method should be used only for charging at low rates (less than  $C/3$ ) to avoid excessive overcharge because the state-of-charge of the battery, prior to charging, cannot always be determined. If a timed charge termination is used, a time of 120 percent charge input is recommended with a backup temperature cutoff of  $60^{\circ}\text{C}$  ( $140^{\circ}\text{F}$ ).

#### 6.2.2 Voltage Drop ( $-\Delta V$ )

Voltage drop is widely used with nickel-cadmium batteries. With this technique, the voltage during charge is monitored and the charge is terminated when the voltage begins to decrease. This approach can be used with nickel-metal hydride batteries, but as noted in Section 6.1, the voltage drop of the nickel-metal hydride battery is not as prominent as that of the nickel-cadmium battery and may be absent in charge currents below the  $C/3$  rate, particularly at elevated temperatures. The voltage sensing circuitry

#### 6.2.3 Voltage Plateau (Zero $\Delta V$ )

Since the nickel-metal hydride battery does not always show an adequate voltage drop, an alternate method used is to terminate the charge when the voltage peaks and the slope is zero, rather than waiting for the voltage to drop. The risk of overcharge is

#### 6.2.4 Temperature Cutoff

Another technique for charge control is to monitor the temperature rise of the battery and terminate the charge when the battery has reached a temperature which indicates the beginning of overcharge. It is difficult, however, to precisely determine this point

FIGURE 6.2.1

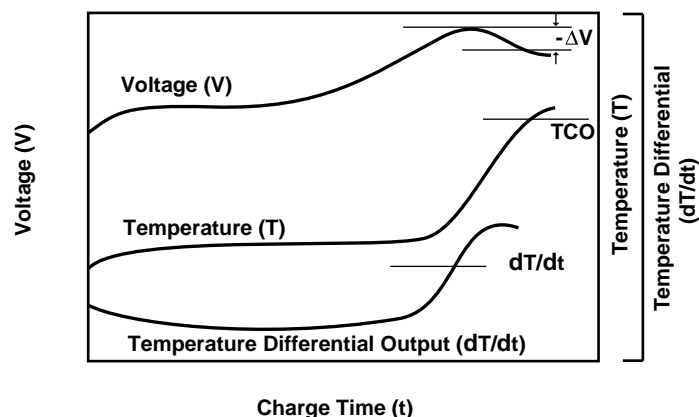

Charge characteristics of Ni-MH batteries using various charge termination methods.

must be sensitive enough to terminate the charge when the voltage drops, but not so sensitive that it will terminate prematurely due to noise or other normal voltage fluctuations. A charge rate of  $1C$  and a 5 to 10 millivolt per cell drop is recommended for the nickel-metal hydride battery with a backup temperature cutoff of  $60^{\circ}\text{C}$  ( $140^{\circ}\text{F}$ ). A top-up charge is not necessary with this charge termination method.

reduced as compared to the  $-\Delta V$  method. If this method is employed, a charge rate of  $1C$  and a backup temperature cutoff of  $60^{\circ}\text{C}$  ( $140^{\circ}\text{F}$ ) is recommended. A top-up charge can follow to ensure a full charge. *Duracell does not recommend this termination method because of the risk of premature cutoff.*

because it is influenced by ambient temperature, cell and battery design, charge rate, and other factors. A cold battery, for instance, may be overcharged before reaching the cutoff temperature, while a warm battery may be undercharged.

## Charging Sealed Nickel-Metal Hydride Batteries (cont.)

### 6.2.4 Temperature Cutoff (cont.)

Usually this method is used in conjunction with other charge control techniques primarily to terminate the charge in the event that the battery reaches excessive temperatures before the other charge controls acti-

vate. A charge rate of 1C and a temperature cutoff at 60°C (140°F) is recommended. A top-up charge is not recommended if this termination method is used.

### 6.2.5 Delta Temperature Cutoff ( $\Delta TCO$ )

This technique measures the battery temperature rise above the starting temperature during charging and terminates the charge when this rise exceeds a predetermined value. In this way, the influence of ambient temperature is minimized. The cutoff value is dependent on several factors, including cell size, configuration and number of cells in the battery, and the heat capacity of the battery. Therefore, the cutoff value should be deter-

mined for each type of battery. This value will be greater for nickel-metal hydride batteries than for nickel-cadmium batteries. A charge rate of 1C and a temperature change of 15°C (27°F) with a backup temperature cutoff of 60°C (140°F) is recommended for  $\Delta TCO$  charge termination. A top-up charge is not necessary with this termination method.

### 6.2.6 Rate of Temperature Increase (dT/dt)

In this method, the change in temperature with time is monitored and the charge is terminated when a predetermined rate of temperature rise is reached. The influence of ambient temperature is reduced. A dT/dt cutoff is a preferred charge control method for nickel-metal hydride batteries because it provides long cycle life. **Figure 6.2.2** shows the advantage of using a dT/dt method compared to  $-\Delta V$  in terminating a fast charge. The dT/dt method senses the start of the overcharge earlier than the  $-\Delta V$  method. The battery is exposed to less overcharge and overheating, resulting in less loss of cycle life. A charge rate of 1C and a temperature increase of 1°C (1.8°F) per minute with a back-up temperature cutoff of 60°C (140°F) is recommended for dT/dt. A top-up charge of C/10 for 1/2 hour is also recommended.

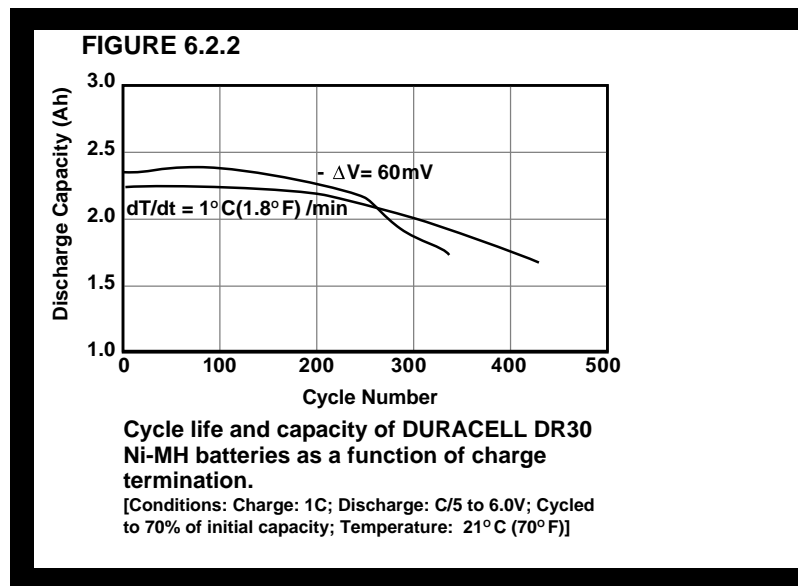

## 6.3 Charging Methods

Nickel-metal hydride batteries can be charged employing the same methods used for charging nickel-cadmium batteries. However, the charge termination technique may differ because of the varying behavior of the two battery systems. For proper charging of nickel-metal hydride batteries, the charge termination technique used should be appropriate for the particular charge rate. The charge rate and appropriate termination technique is summarized in **Table 6.3.1**.

Some of the various methods used to properly charge nickel-metal hydride batteries are explained in

Sections 6.3.1 to 6.3.5. In order to optimize performance, Duracell recommends a three-step charge procedure.

Charge Rate	Termination Technique
1C to C/2	Voltage or temperature based
C/2 to C/3	Voltage based
C/3 to C/10	Not recommended
C/10 and below	Time limited

Table 6.3.1 Recommended charge termination techniques for particular charge rates.

## ***Charging Sealed Nickel-Metal Hydride Batteries (cont.)***

### **6.3.1 Duracell's Recommendation: Three-Step Charge Procedure**

For fast charging and optimum performance, Duracell recommends a three-step procedure that provides a means of rapidly charging a nickel-metal hydride battery to full charge without excessive overcharging or exposure to high temperatures. The steps in sequential order are:

- 1) Charge at the 1C rate, terminated by using  $dT/dt = 1^{\circ}\text{C}(1.8^{\circ}\text{F})/\text{minute}$ .
- 2) Apply a C/10 top-up charge, terminated by a timer after 1/2 hour of charge.
- 3) Apply a maintenance charge of indefinite duration at C/300 rate.

The three-step charging method should be used with a backup temperature cutoff of  $60^{\circ}\text{C}(140^{\circ}\text{F})$ .

### **6.3.2 Low-Rate Charge ( $\approx 12$ hours)**

Charging at a constant current at the C/10 rate with time-limited charge termination is a convenient method to fully charge nickel-metal hydride batteries. At this current level, the generation of gas will not exceed the oxygen recombination rate. The charge should be terminated after 120 percent charge input, or approximately 12 hours for a fully discharged battery.

Excessive overcharging should be avoided, as it can damage the battery.

The temperature range for this charge method is  $0^{\circ}\text{C}$  to  $45^{\circ}\text{C}$  ( $32^{\circ}\text{F}$  to  $113^{\circ}\text{F}$ ), with optimum performance being obtained between  $15^{\circ}\text{C}$  to  $30^{\circ}\text{C}$  ( $59^{\circ}\text{F}$  to  $86^{\circ}\text{F}$ ).

### **6.3.3 Quick Charge ( $\approx 4$ hours)**

Nickel-metal hydride batteries can be efficiently and safely charged at higher rates than described in Section 6.3.2. Charge control is required in order to terminate the charge when the rate of oxygen recombination is exceeded or the battery temperature rises excessively. A fully discharged battery can be charged at the C/3 rate terminated with a  $-\Delta V = 10$  mV/cell. In addition, a timer control set to a 120 percent charge input (3.6 hours) and a temperature cutoff of  $60^{\circ}\text{C}$  ( $140^{\circ}\text{F}$ ) should be used as a backup termination to

avoid exposing the battery to excessively high temperatures. This charging method may be used in an ambient temperature range of  $10^{\circ}\text{C}$  to  $45^{\circ}\text{C}$  ( $50^{\circ}\text{F}$  to  $113^{\circ}\text{F}$ ). A top-up charge is not necessary if this termination method is used.

At the C/3 rate, a  $dT/dt$  termination method should not be used because the rate of temperature increase may not be sufficient to terminate the charge.

### **6.3.4 Fast Charge ( $\approx 1$ hour)**

Another method of charging nickel-metal hydride batteries in even less time is to charge at the C/2 to 1C constant current rates. At these high charge rates, it is essential that the charge be terminated early during overcharge. However, timer control is inadequate, as the time needed for charge can not be predicted — a partially charged battery could easily be overcharged while a fully discharged one could be undercharged, depending on how the timer control is set.

With fast charging, the decrease in voltage ( $-\Delta V$ ) and the increase in temperature ( $\Delta T$ ) can be used to terminate the charge. For better results, termination of fast charge can be controlled by sensing the rate of temperature increase ( $dT/dt$ ). A temperature increase of  $1^{\circ}\text{C}$  ( $1.8^{\circ}\text{F}$ ) per minute with a backup temperature cutoff of  $60^{\circ}\text{C}$  ( $140^{\circ}\text{F}$ ) is recommended. A top-up charge of C/10 for 30 minutes should follow to ensure a full charge.

## **Charging Sealed Nickel-Metal Hydride Batteries (cont.)**

### **6.3.5 Trickle Charge**

A number of applications require the use of batteries which are maintained in a fully-charged state. This is accomplished by trickle charging at a rate that will replace the loss in capacity due to self-discharge. In these applications, a trickle charge at a C/300 rate is

recommended. The preferred temperature range for trickle charging is between 10°C to 35°C (50°F to 95°F). Trickle charge may be used following any of the previously discussed charging methods.

### **6.4 Thermal Devices**

DURACELL nickel-metal hydride batteries contain a temperature sensing device and thermal protective devices. Thermal protective devices terminate charge/discharge in the event high temperatures are reached. This protection is particularly important when fast charging methods are used. The types of devices used are:

- 1) Negative Temperature Coefficient (NTC) Thermistor:** This device senses internal battery temperature and provides this information by means of a calibrated resistance value to an external control circuit. The thermistor is attractive because the control can be set, external to the battery, to meet the particular conditions of the charge. This device is used in dT/dt charge control.
- 2) Thermostat:** This bimetal thermal protective device operates at a fixed temperature and is used to cut off the charge (or discharge) when a pre-established internal battery temperature or current is reached. These temperature cutoff (TCO) devices reset automatically after the overtemperature or over-current condition has decreased below a reset threshold.
- 3) Thermal Fuse:** This device is wired in series with the cell stack and will open the circuit when a predetermined temperature is reached. Thermal fuses are included as a protection against thermal runaway and are normally set to open at approximately 91°C (196°F). This device cannot be reset once opened.

#### **4) Positive Temperature Coefficient (PTC)**

**Device:** This is a resettable device whose resistance rapidly increases at a predetermined current, thereby reducing the current in the battery to a low and acceptable level. The PTC device will respond to high current beyond design limits (e.g. a short circuit) and acts like a fuse. Unlike a one-time fuse, the PTC device will reset to its low resistance state when the latching current is removed. It will also respond to high temperatures around the PTC device, in which case it operates like a temperature cut-off (TCO) device.

The location of thermal devices in the battery assembly is critical to ensure that they will respond properly as the temperature may not be uniform throughout the battery. Thermal devices in DURACELL nickel-metal hydride batteries are set so the cells are not exposed to temperatures above 91°C (196°F). The inclusion of thermal protective devices in DURACELL nickel-metal hydride batteries helps ensure safe battery operation.

# DURACELL *TIPS*

***TECHNICAL INFORMATION & PRODUCT SPECIFICATIONS***



**Print Output:** Ni-MH Technical Bulletin

Chapter: 7

Pages: 3 (not including this page)

# T able of Contents

---

## 1 Introduction

---

## 2 General Characteristics

---

## 3 Composition and Chemistry

- 3.1 Active Components: Positive and Negative Electrodes
  - 3.2 Electrolyte
  - 3.3 Cell Reactions
- 

## 4 Battery Construction

- 4.1 Basic Cell Construction
  - 4.2 Cylindrical Cell Construction
  - 4.3 Prismatic Cell Construction
- 

## 5 Performance Characteristics

- |   |  |
|---|--|
| 5.1 General Characteristics   | 5.5 Constant Power Discharge Characteristics |
| 5.2 Discharge Characteristics: Effect of Discharge Rate and Temperature | 5.6 Polarity Reversal During Overdischarge   |
| 5.3 Capacity: Effect of Discharge Rate and Temperature                  | 5.7 Internal Impedance                       |
| 5.4 Energy Density  | 5.8 Self-Discharge and Charge Retention      |
|   | 5.9 Voltage Depression (“Memory Effect”)     |
- 

## 6 Charging Sealed Nickel-Metal Hydride Batteries

- |   |   |
|---|---|
| 6.1 General Principles                          | 6.3 Charging Methods  |
| 6.2 Techniques for Charge Control               | 6.3.1 Duracell’s Recommendation:<br>Three-Step Charge Procedure |
| 6.2.1 Timed Charge                              | 6.3.2 Low-Rate Charge   |
| 6.2.2 Voltage Drop ( $-\Delta V$ )              | 6.3.3 Quick Charge  |
| 6.2.3 Voltage Plateau (zero $\Delta V$ )        | 6.3.4 Fast Charge   |
| 6.2.4 Temperature Cutoff                        | 6.3.5 Trickle Charge  |
| 6.2.5 Delta Temperature Cutoff ( $\Delta TCO$ ) | 6.4 Thermal Devices   |
| 6.2.6 Rate of Temperature Increase ( $dT/dt$ )  |   |
- 

## 7 Cycle and Battery Life

- 7.1 Cycle Life
  - 7.2 Battery Life
- 

## 8 Safety Considerations

---

## 9 Proper Use and Handling

- 9.1 Care and Handling
- 9.2 Transportation
- 9.3 Waste Management: Recycling and Disposal



# 7

## Cycle and Battery Life

### 7.1 Cycle Life

The cycle life of nickel-metal hydride batteries depends on the many conditions to which the battery has been exposed, as is true for all types of rechargeable batteries. These include such variables as:

- Temperature during charge and discharge
- Charge and discharge current
- Depth of discharge
- Method of charge control
- Exposure to overcharging and overdischarging
- Storage conditions

Typically, under a C/5 charge/discharge at normal ambient temperatures (20°C or 68°F), up to 500 cycles can be achieved with the battery delivering at least 80 percent of its rated capacity. The gradual decrease in capacity results from an increase in the battery's internal resistance, caused by minor irreversible changes in the structure of the electrodes, electrolyte distribution and separator dry-out.

For optimum battery life and maximum cycle life, nickel-metal hydride batteries should be operated at or near room temperature (20°C or 68°F). Repeated operation at extreme temperatures during charge and discharge will adversely affect the performance of the cells (and thus the battery), as shown graphically in **Figure 7.1.1**. Operation at high temperatures, particularly in the overcharged condition, can cause the cell to vent, releasing gas and possibly electrolyte through the safety vent. High temperatures will also hasten the deterioration of the separator and other materials in the cell. At temperatures below 0°C (32°F), the oxygen recombination reaction slows down and the cell is more sensitive to overcharging, thus gas pressure will build up more rapidly.

**FIGURE 7.1.1**

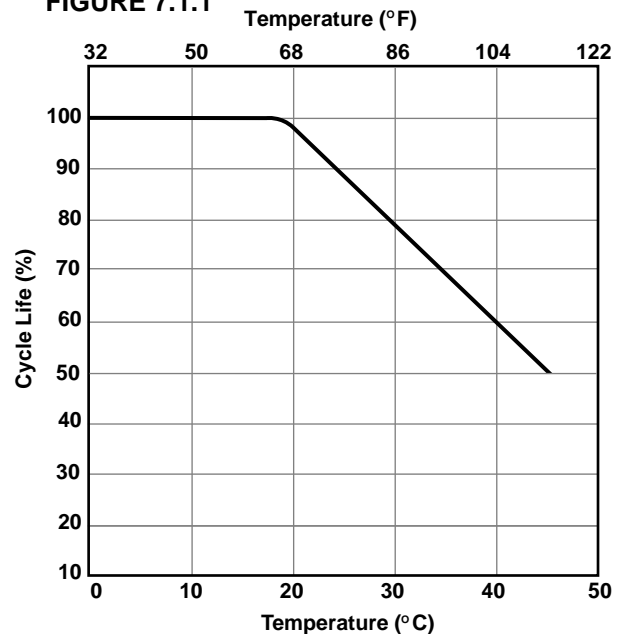

**Impact on cycle life from repeated charging and discharging at various ambient temperatures.**

[Conditions: Charge: C/4 for 3.2 hours; Discharge: C/4 for 2.4 hours; Capacity measured every 50 cycles @ 21°C (70°F); Charge: C/3 for 5 hours; Discharge: 1C to 1.0V]

## *Cycle and Battery Life (cont.)*

Charge rate and amount of charge input during overcharging are also important factors affecting cycle life. If the battery is charged at a rate that exceeds the oxygen recombination rate, oxygen that is generated during overcharge will not react, causing a build up in gas pressure and a rise in temperature which will have damaging effects on battery and cycle life. Prompt use of an effective charge termination method when deleterious overcharge begins will lessen the effect on cycle life.

Cycle life is also affected by the depth of discharge. Depending upon the charge termination method, up to 500 cycles can be obtained with the battery being fully discharged on each cycle (100 percent depth of discharge, or “DOD”). Considerably higher cycle life can be obtained if the battery is cycled at shallower charge/discharges.

### **7.2 Battery Life**

The same factors that affect cycle life affect overall battery life. Operation or storage at extreme temperatures, overcharging, cell venting and abusive use will reduce battery life. Operation and storage of

batteries at or about room temperature (20°C or 68°F) will maximize battery life. Recommended and permissible temperature limits are shown in **Table 7.2.1**.

**Table 7.2.1**

	<b>Recommended</b>	<b>Permissible</b>
Low Rate Charge	15°C to 30°C (59°F to 86°F)	0°C to 45°C (32°F to 113°F)
Quick Charge	10°C to 30°C (50°F to 86°F)	10°C to 45°C (50°F to 113°F)
Fast Charge	10°C to 30°C (50°F to 86°F)	10°C to 45°C (50°F to 113°F)
Trickle Charge	10°C to 30°C (50°F to 86°F)	10°C to 35°C (50°F to 95°F)
Discharge	0°C to 40°C (32°F to 104°F)	- 20°C to 50°C (-4°F to 122°F)
Storage, Short Term	10°C to 30°C (50°F to 86°F)	- 20°C to 50°C (-4°F to 122°F)
Storage, Long Term	10°C to 30°C (50°F to 86°F)	- 20°C to 35°C (-4°F to 95°F)

Table 7.2.1 Recommended and permissible temperature limits for operation and storage of DURACELL nickel-metal hydride rechargeable batteries.

# DURACELL *TIPS*

***TECHNICAL INFORMATION & PRODUCT SPECIFICATIONS***



**Print Output:** Ni-MH Technical Bulletin

Chapter: 8

Pages: 3 (not including this page)

# T able of Contents

---

## 1 Introduction

---

## 2 General Characteristics

---

## 3 Composition and Chemistry

- 3.1 Active Components: Positive and Negative Electrodes
  - 3.2 Electrolyte
  - 3.3 Cell Reactions
- 

## 4 Battery Construction

- 4.1 Basic Cell Construction
  - 4.2 Cylindrical Cell Construction
  - 4.3 Prismatic Cell Construction
- 

## 5 Performance Characteristics

- |   |  |
|---|--|
| 5.1 General Characteristics   | 5.5 Constant Power Discharge Characteristics |
| 5.2 Discharge Characteristics: Effect of Discharge Rate and Temperature | 5.6 Polarity Reversal During Overdischarge   |
| 5.3 Capacity: Effect of Discharge Rate and Temperature                  | 5.7 Internal Impedance                       |
| 5.4 Energy Density  | 5.8 Self-Discharge and Charge Retention      |
|   | 5.9 Voltage Depression (“Memory Effect”)     |
- 

## 6 Charging Sealed Nickel-Metal Hydride Batteries

- |   |   |
|---|---|
| 6.1 General Principles                          | 6.3 Charging Methods  |
| 6.2 Techniques for Charge Control               | 6.3.1 Duracell’s Recommendation:<br>Three-Step Charge Procedure |
| 6.2.1 Timed Charge                              | 6.3.2 Low-Rate Charge   |
| 6.2.2 Voltage Drop ( $-\Delta V$ )              | 6.3.3 Quick Charge  |
| 6.2.3 Voltage Plateau (zero $\Delta V$ )        | 6.3.4 Fast Charge   |
| 6.2.4 Temperature Cutoff                        | 6.3.5 Trickle Charge  |
| 6.2.5 Delta Temperature Cutoff ( $\Delta TCO$ ) | 6.4 Thermal Devices   |
| 6.2.6 Rate of Temperature Increase ( $dT/dt$ )  |   |
- 

## 7 Cycle and Battery Life

- 7.1 Cycle Life
  - 7.2 Battery Life
- 



## 8 Safety Considerations

---

## 9 Proper Use and Handling

- 9.1 Care and Handling
- 9.2 Transportation
- 9.3 Waste Management: Recycling and Disposal

# 8

## *Safety Considerations*

Duracell's nickel-metal hydride batteries are designed to ensure maximum safety. Each cell includes a resealable pressure relief mechanism (safety vent) to prevent excessive build-up of pressure in the cell in the event it is overcharged excessively, exposed to extreme high temperatures, or otherwise abused. Duracell's nickel-metal hydride batteries contain protective devices, as discussed in Section 6.4, to prevent excessive heating during fast charging, high rate discharging beyond design limits, or abusive use.

DURACELL nickel-metal hydride batteries have been tested by the Underwriters Laboratories in accordance with UL Standard 2054 "Outline of Investigation for Household and Commercial Batteries." Duracell successfully met all of the test criteria. The tests required under this Standard and the results of the tests on DURACELL cells and batteries are summarized in **Table 8.0.1**. These tests cover operational and abusive conditions to which batteries may be exposed during their use.

DURACELL nickel-metal hydride cells and batteries that are listed by Underwriters Laboratories under UL Standard 2054 are identified in File No. MH17905. Some DURACELL nickel-metal hydride batteries used in computers are listed under UL Standard 1950 "Safety of Information Technology Equipment, including Electrical Business Equipment," and are identified in File No. E158164.

***Safety Considerations (cont.)***

**Table 8.0.1**

<b>Test</b>	<b>Test Conditions</b>	<b>Test Results</b>
Flat Plate Crush Test	Cell is crushed between two flat surfaces.	No explosion, sparks, or flames.
Impact Test	A 20 lb. weight is dropped from height of 2 feet on cell.	No explosion, sparks, or flames.
Short Circuit Test*	Sample is shorted until discharged. Test conducted at 20°C and 60°C (68°F and 140°F).	No evidence of venting, leakage, bulging or other visible changes on individual cells. Maximum case temperature was 129°C (264°F). In batteries, safety devices operated, protecting battery from external short. Maximum battery case temperature was within 5°C (41°F) of ambient.
Forced-Discharge Test (Voltage Reversal)	The cell, after discharge, is over-discharged for 1.5 times rated capacity.	No venting, leakage, fire or explosion on test conducted at C/3 discharge rate.
Abnormal Charge Test	Cell is charged for 2.5 times rated capacity.	No venting, leakage, fire or explosion on test conducted at C/3 charge rate.
Abusive Overcharge Test*	Sample is charged by power supply up to 200 watts until sample vents or explodes.	Individual cells vented. No explosion or fire. Maximum temperature on cell case was 200°C (392°F). In batteries, safety devices caused charging circuit to open periodically, protecting battery as designed. Maximum battery case temperature was within 25°C (77°F) of ambient.
Heat Test	The cell is heated in an oven to 150°C (302°F).	No damage to cells; no bulging, venting, fire or explosion.
Fire Exposure Test*	Sample is heated by a burner fueled with methane.	Cells and batteries vented without exploding. No significant flaming or spark. No projectiles.

Table 8.0.1 Results of DURACELL nickel-metal hydride cells and/or batteries tested under UL Standard 2054 test regimes.

\*Note: These tests were conducted on both individual cells and batteries. Tests *not* marked with an asterisk were conducted on individual cells only, as deemed adequate by UL to demonstrate safety of both cells and batteries.

# DURACELL *TIPS*

***TECHNICAL INFORMATION & PRODUCT SPECIFICATIONS***



**Print Output:** Ni-MH Technical Bulletin

Chapter: 9

Pages: 3 (not including this page)

# T able of Contents

---

## 1 Introduction

---

## 2 General Characteristics

---

## 3 Composition and Chemistry

- 3.1 Active Components: Positive and Negative Electrodes
  - 3.2 Electrolyte
  - 3.3 Cell Reactions
- 

## 4 Battery Construction

- 4.1 Basic Cell Construction
  - 4.2 Cylindrical Cell Construction
  - 4.3 Prismatic Cell Construction
- 

## 5 Performance Characteristics

- |   |  |
|---|--|
| 5.1 General Characteristics   | 5.5 Constant Power Discharge Characteristics |
| 5.2 Discharge Characteristics: Effect of Discharge Rate and Temperature | 5.6 Polarity Reversal During Overdischarge   |
| 5.3 Capacity: Effect of Discharge Rate and Temperature                  | 5.7 Internal Impedance                       |
| 5.4 Energy Density  | 5.8 Self-Discharge and Charge Retention      |
|   | 5.9 Voltage Depression (“Memory Effect”)     |
- 

## 6 Charging Sealed Nickel-Metal Hydride Batteries

- |   |   |
|---|---|
| 6.1 General Principles                          | 6.3 Charging Methods  |
| 6.2 Techniques for Charge Control               | 6.3.1 Duracell’s Recommendation:<br>Three-Step Charge Procedure |
| 6.2.1 Timed Charge                              | 6.3.2 Low-Rate Charge   |
| 6.2.2 Voltage Drop ( $-\Delta V$ )              | 6.3.3 Quick Charge  |
| 6.2.3 Voltage Plateau (zero $\Delta V$ )        | 6.3.4 Fast Charge   |
| 6.2.4 Temperature Cutoff                        | 6.3.5 Trickle Charge  |
| 6.2.5 Delta Temperature Cutoff ( $\Delta TCO$ ) | 6.4 Thermal Devices   |
| 6.2.6 Rate of Temperature Increase ( $dT/dt$ )  |   |
- 

## 7 Cycle and Battery Life

- 7.1 Cycle Life
  - 7.2 Battery Life
- 

## 8 Safety Considerations

---

## 9 Proper Use and Handling

- 9.1 Care and Handling
- 9.2 Transportation
- 9.3 Waste Management: Recycling and Disposal



# 9

## ***Proper Use and Handling***

Nickel-metal hydride batteries can give years of safe and reliable service if they are used in accordance with recommended procedures and are not abused. The batteries can be used in any operating position. Other than charging, the only maintenance that should be required is to keep them clean and dry both during use and storage.

As previously discussed, nickel-metal hydride batteries, as with all battery systems, should not be exposed to extreme temperatures for any long period of time. They can be stored for many months in a charged or discharged state without any detrimental effects. Storage and operation at normal room temperatures is preferred, but wider temperatures can be safely tolerated as discussed in detail in this bulletin.

DURACELL nickel-metal hydride batteries are shipped in a partially charged state. Therefore, caution should be exercised to avoid short-circuiting the battery during handling.

After storage or periods during which the battery has not been used, the battery should be charged, using any of the methods discussed in this bulletin, before being placed in service. Extended overcharging or overheating of the battery should always be avoided.

The care and handling procedures outlined in the following section should be carefully followed.

---

### **9.1 Care and Handling**

#### **Disassembly**

The battery should not be disassembled, opened or shredded under any conditions — high short circuit currents and fire could result. Nickel-metal hydride cells contain an alkaline electrolyte which can cause injury. In the event that the electrolyte comes into contact with skin or eyes, immediately flush with fresh water and seek medical advice.

#### **Handling**

DURACELL nickel-metal hydride batteries are designed to withstand normal handling. They should not be dropped or subjected to strong mechanical shock.

#### **High Temperatures/Fire**

Never subject the battery to heat or dispose of it in a fire — the battery can explode, leak or burn if exposed to fire or very high temperatures. For optimum life, batteries should be shielded from or placed away from heat sources. See Section 7.2 which describes recommended temperatures for use, operation and storage of nickel-metal hydride batteries.

#### **Vented Battery Compartments**

It is possible that cells may vent if the battery is overcharged or otherwise abused. Nickel-metal hydride cells release hydrogen gas during venting which could form potentially explosive mixtures with air. Caution should be exercised to prevent the gas from collecting in the battery or equipment. Exposure to a source of ignition and airtight device compartments should be avoided.

#### **Severe Use Applications**

Short-term use of nickel-metal hydride batteries outside of specified ranges may be possible. Please consult Duracell if such a requirement exists.

## ***Proper Use and Handling (cont.)***

### **9.2 Transportation**

Procedures for the transportation of batteries are specified by the United States Department of Transportation in the “Code of Federal Regulations,” CFR49, entitled “Transportation.” Internationally, air transportation is specified by the International Civil Aviation Organization (ICAO) in their publication “Technical Instructions for the Safe Transport of

Dangerous Goods By Air.”

The nickel-metal hydride battery supplied by Duracell is recognized by the regulatory agencies as a “dry battery.” As such, it is not subject to regulation and can be shipped in normal packaging and transported on any mode of transportation without special handling.

### **9.3 Waste Management: Recycling and Disposal**

The management of waste products in the United States is regulated by the U.S. Environmental Protection Agency (EPA). The EPA Regulations are listed in the “Code of Federal Regulations”, CFR40, entitled “Protection of Environment.” Individual states and local communities also may establish regulations covering the disposal of waste products. These may be more stringent than the federal regulations and cover the management of household waste, which is not included in the federal regulations.

The U.S. EPA has not provided any specific regulations or guidelines for the waste management of sealed nickel-metal hydride cells or batteries. As a result, a number of states and local governments have passed or are considering legislation which may require special procedures for the disposal of these batteries. Thus, state and local agencies should be contacted for their waste management guidelines. Internationally, procedures for waste management may vary from country to country.

In the absence of regulations or guidelines, the following is recommended for recycling and disposing of used nickel-metal hydride batteries:

#### **A) Recycling;**

Duracell encourages the recycling of DURACELL nickel-metal hydride batteries and offers a special worldwide recycling program. For information on recycling DURACELL nickel-metal hydride rechargeable batteries, please contact your nearest Duracell office. In North America, call toll-free 1-800-551-2355 (9:00 a.m. to 5:00 p.m. E.S.T.).

#### **B) Disposal:**

*Household Use* – Individual batteries can be disposed of with other household wastes.

*Commercial Use* – When ten or more batteries are accumulated, the commercial user may want to consider disposing the batteries in a secure waste landfill. Since these batteries are not classified as a “hazardous waste,” they can be shipped to the secure waste facility as “non-hazardous waste.”

Local regulations, which specify other methods for the disposal of nickel-metal hydride batteries, supersede these recommendations. Waste management companies can provide assistance for the disposal of these batteries. As previously stated, nickel-metal hydride batteries should not be disassembled, opened or shredded.